

DM-918

OPERATIONS MANUAL

AUTORANGING MULTIMETER

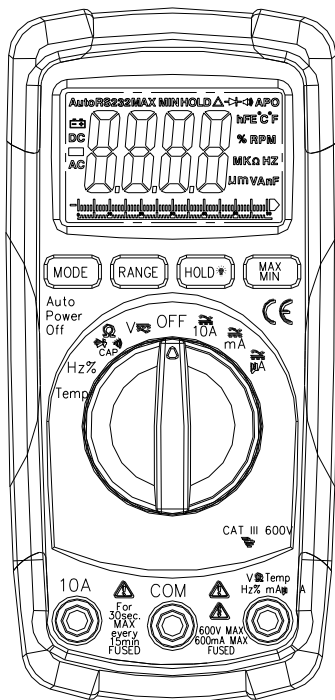

SAFETY INFORMATION

The following safety information must be observed to ensure maximum personal safety during the operation of this meter:

- This meter is designed for use by trained and qualified professionals only.
- Do not use the meter if the meter or test leads look damaged or if you suspect that the meter is not operating properly.
- Never ground yourself when taking electrical measurements. Do not touch exposed metal pipes, outlets, fixtures, etc., which might Act as a potential ground. Keep your body isolated from grounding by using dry clothing, rubber soled shoes, rubber mats or any approved insulating material.
- Turn off power to the circuit under test before cutting, unsoldering or breaking the circuit. Small amounts of current can be dangerous.
- Use caution when making measurements if voltage is above 25VAC RMS or 35VDC. These voltages are considered a shock hazard.
- When using test lead probes, always keep your fingers behind the finger guard on the probe.
- Measuring voltage which exceeds the limits of the multimeter may damage the meter and expose the operator to a shock hazard. Always recognize the meter voltage limits as stated on the front of the meter.
- Never apply voltage or current to the meter that exceeds the specified maximum.

SAFETY SYMBOLS



This symbol adjacent to another symbol, terminal or operating device indicates that the operator must refer to an explanation in the Operating Instructions to avoid personal injury or damage to the meter.



This **WARNING** symbol indicates a potentially hazardous situation which, if not avoided, could result in death or serious injury.



This **CAUTION** symbol indicates a potentially hazardous situation which, if not avoided, may result damage to the product.



This symbol advises the user that the terminal(s) so marked must not be connected to a circuit point at which the voltage exceeds (in this case) 500 VAC or VDC.



This symbol adjacent to one or more terminals identifies them as being associated with ranges that may, in normal use, have particularly hazardous voltages present. For maximum safety, the meter and its test leads should not be handled when these terminals are energized.

METER DESCRIPTION

1. 6,000 count Liquid Crystal Display with symbolic signs
2. Function Dial
3. Positive Input Jack
4. COM (negative) Input Jack
5. 10A (positive) Input Jack for 10A DC or AC measurements
6. Measuring MODE selection button.
7. Range button
8. Hold/Backlight button
9. MAX/Min Hold button

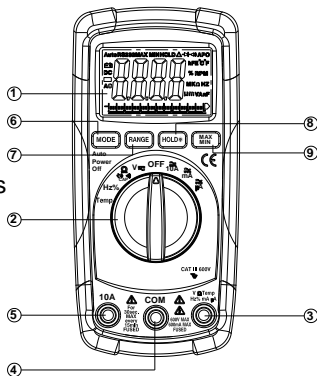

DISPLAY DESCRIPTION

-))) Continuity
- ⊖+ Low Battery
- ▶ Diode
- HOLD Data Hold
- AUTO Autoranging
- AC Alternating Current or Voltage
- DC Direct Current or Voltage

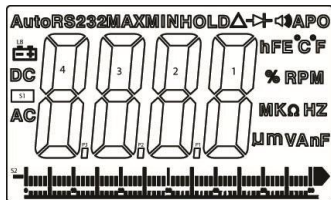

SPECIFICATIONS

The instrument complies with: EN61010-1.

Insulation: Class 2, Double insulation.

Overvoltage category: CATIII 600V.

Display: 6000 counts LCD display with function indication.

Polarity: Automatic, (-) negative polarity indication.

Over range: "OL" mark indication.

Low battery indication: The "  " is displayed when the battery voltage drops below the operating level.

Measurement rate: 3 times per second, nominal.

Auto power off: Meter automatically shuts down after approx. 15 minutes of inactivity.

Operating environment: 0 °C to 50 °C (32 °F to 122 °F) at < 70 % relative humidity.

Storage temperature: -20 °C to 60 °C (-4 °F to 140 °F) at < 80 % relative humidity.

For inside use, max height: 2000m

Pollution degree: 2

Power: One 9V battery , NEDA 1604, IEC 6F22.

Dimensions: 138 (H) x 68 (W) x 37 (D) mm

Weight: Approx.: 210g.

Approvals: CE, 

Accuracy is determined at 18 °C to 28 °C (65 °F to 83 °F), less than 70 % RH

DC Voltage (Autoranging)

Range	Resolution	Accuracy
600.0mV	0.1mV	$\pm 0.5\%$ of rdg ± 2 dgts
6.000V	1mV	$\pm 1.2\%$ of rdg ± 2 dgts
60.00V	10mV	
600.0V	100mV	
600V	1V	$\pm 1.5\%$ of rdg ± 4 dgts

Input Impedance: 10M Ω .

Maximum Input: 600V DC or 600V AC RMS.

AC Voltage (Autoranging except 600mV)

Range	Resolution	Accuracy
6.000V	1mV	$\pm 1\%$ of rdg ± 3 dgts
60.00V	10mV	$\pm 1.2\%$ of rdg ± 3 dgts
600.0V	100mV	
600.0V	1V	

Input Impedance: 10M Ω

Frequency Range: 50 to 400Hz

Maximum Input: 600V DC or 600V AC RMS.

DC Current (Autoranging for μ A and mA)

Range	Resolution	Accuracy
600.0 μ A	0.1 μ A	$\pm 1.0\%$ of rdg ± 3 dgts
6000 μ A	1 μ A	$\pm 1.5\%$ of rdg ± 3 dgts
60.00mA	10 μ A	
600.0mA	100 μ A	
10A	10mA	$\pm 2.5\%$ of rdg ± 5 dgts

Overload Protection: 0.8A / 250V and 10A / 250V Fuse.

Maximum Input: 600mA DC or 600mA AC RMS on μ A / mA ranges, 10A DC or AC RMS on 10A range.

AC Current (Autoranging for μA and mA)

Range	Resolution	Accuracy
600.0 μA	0.1 μA	$\pm 1.5\%$ of rdg ± 5 dgts
6000 μA	1 μA	$\pm 1.8\%$ of rdg ± 5 dgts
60.00mA	10 μA	
600.0mA	100 μA	
10A	10mA	$\pm 3.0\%$ of rdg ± 7 dgts

Overload Protection: 0.8A / 250V and 10A / 250V Fuse.

Frequency Range: 50 to 400 Hz

Maximum Input: 600mA DC or 600mA AC RMS on μA / mA ranges, 10A DC or AC RMS on 10A range.

Resistance (Autoranging)

Range	Resolution	Accuracy
600.0 \square	0.1 Ω	$\pm 1.2\%$ of rdg ± 4 dgts
6.000k \square	1 Ω	$\pm 1.0\%$ of rdg ± 2 dgts
60.00k \square	10 Ω	$\pm 1.5\%$ of rdg ± 2 dgts
600.0k \square	100 Ω	
6.000M \square	1k Ω	
60.00M \square	10k Ω	$\pm 2.0\%$ of rdg ± 3 dgts

Input Protection: 250V DC or 250V AC RMS.

Capacitance (Autoranging)

Range	Resolution	Accuracy
40.00nF	10pF	$\pm 5.0\%$ of rdg ± 20 dgts
400.0nF	0.1nF	$\pm 3.0\%$ of rdg ± 5 dgts
4.000 μF	1nF	
40.00 μF	10nF	
400.0 μF	0.1 μF	$\pm 5.0\%$ of rdg ± 5 dgts
1000.0 μF^*	1 μF	$\pm 10.0\%$ of rdg ± 5 dgts

Input Protection: 250V DC or 250V AC RMS.

Frequency (Autoranging)

Range	Resolution	Accuracy
9.999Hz	0.001Hz	± 1.5% of rdg ± 5 dgts
99.99Hz	0.01Hz	
999.9Hz	0.1Hz	± 1.2% of rdg ± 3 dgts
9.999kHz	1Hz	
99.99kHz	10Hz	
999.9kHz	100Hz	
9.999MHz	1kHz	± 1.5% of rdg ± 4 dgts

Sensitivity: >8V RMS

Overload protection: 250V DC or AC RMS.

Duty Cycle

Range	Resolution	Accuracy
0.1%~99.9%	0.1%	±1.2% of rdg ± 2 dgts

Pulse width: >100us, <100ms;

Frequency width: 5Hz – 150kHz

Sensitivity: >8V RMS

Overload protection: 250V DC or AC RMS

Temperature

Range	Resolution	Accuracy
-20°C ~+400°C	0.1 °C	± 3% of rdg ± 5 °C
400°C ~+760°C	1 °C	
-4 °F ~+750 °F	0.1°F	± 3% of rdg ± 5 °F
750°F ~+1400 °F	1°F	

Sensor: Type K Thermocouple

Overload protection: 250V DC or AC RMS.

Diode Test

Test current	Resolution	Accuracy
0.3mA typical	1 mV	$\pm 10\%$ of rdg ± 5 dgts

Open circuit voltage: 2V DC typical

Overload protection: 250V DC or AC RMS.

Audible continuity

Audible threshold: Less than 40Ω Test current: $<0.3\text{mA}$

Overload protection: 250V DC or AC RMS.

OPERATION

WARNING: Risk of electrocution. High-voltage circuits, both AC and DC, are very dangerous and should be measured with great care. Follow all applicable safety practices and procedures at all times.

1. ALWAYS turn the function dial to the OFF position when the meter is not in use. This meter has an **Auto Power Off** function that automatically shuts the meter OFF after 15 minutes of inactivity.
2. If "OL" appears in the display during a measurement, the value exceeds the range you have selected. Change to a higher range.

NOTE: On some low AC and DC voltage ranges, with the test leads not connected to a device, the display may show a random, changing reading. This is normal and is caused by the high-input sensitivity. The reading will stabilize and give a proper measurement when connected to a circuit.

MODE BUTTON

1. To select DC/AC current, voltage, resistance, capacitance,

Diode/Continuity, °C /°F or Hz/duty

2. To disable **Auto Power Off**, hold **MODE** button then turn on the DM-918. The **Auto Power Off** function will be cancelled. The “**APO**” icon will not appear in the upper right corner of LCD display. To enable **Auto Power Off**, turn DM-918 off and then back on. This will reset **Auto Power Off** function. The “**APO**” icon will now appear in the upper right corner of LCD display.

RANGE BUTTON

When the meter is first turned on, it automatically goes into Autoranging. This automatically selects the best range for the measurements being made and is generally the best mode for most measurements. For measurement situations requiring that a range be manually selected, perform the following:

1. Press the RANGE button. The “AUTO” display indicator will turn off.
2. Press the RANGE button to step through the available ranges until you select the range you want.
3. Press and hold the RANGE button for 2 seconds to exit Manual Ranging mode and return to Autoranging.

DATA HOLD BUTTON

The Data Hold function allows the meter to hold or "freeze" a measurement for later reference.

1. Press the **HOLD** button to “freeze” the reading on the indicator. The **HOLD** icon will appear on the display.
2. Press the **HOLD** button again to return to normal

operation.

3. To enable or disable the back light function, press and hold the **HOLD** button for 2 seconds.

MAX/MIN BUTTON

The meter displays the maximum or minimum value of input in the **Max/Min** mode. When **Max/Min** is pressed for the first time, the meter displays the maximum value. The meter displays the minimum value when **MAX/MIN** is pressed again. When **Max/Min** is pressed for the third time, the meter displays current value. The meter returns to normal operation when **Max/Min** is pressed and held for two seconds. A value can be held in the Max/Min function by pressing the **HOLD** button.

DC VOLTAGE MEASUREMENTS

CAUTION: Do not measure DC voltages if a motor on the circuit is being switched ON or OFF. Large voltage surges may occur that can damage the meter.

1. Set the function dial to the **V** position, the meter default mode is the DC mode. ("mV" will appear in the display). If the meter does not default to DC mode, press the **MODE** button to select the DC mode.
2. Insert the black test lead into the negative **COM** jack and the red test lead into the positive **V** jack.
3. Touch the test probe tips to the circuit under test. Be sure to observe the correct polarity (red lead to positive, black lead to negative).
4. Read the voltage value on the display. The display will indicate the proper decimal point and value. If the polarity is reversed, the display will show a minus (-) symbol

before the value.

AC VOLTAGE MEASUREMENTS

WARNING: Risk of Electrocution. The probe tips may not be long enough to contact the live parts inside some 240V outlets for appliances because the contacts are recessed deep in the outlets. As a result, the reading may show 0 volts when the outlet actually has voltage on it. Make sure the probe tips are touching the metal contacts inside the outlet before assuming no voltage is present.

CAUTION: Do not measure AC voltages if a motor on the circuit is being switched ON or OFF. Large voltage surges may occur that can damage the meter.

1. Set the function dial to the **V** position and press the **MODE** key to select the AC mode.
2. Insert the black test lead into the negative **COM** jack and the red test lead into the positive **V** jack.
3. Touch the test probe tips to the circuit under test.
4. Read the voltage value on the display. The display will indicate the proper decimal point, value and symbol (AC, V, etc.).

DC CURRENT MEASUREMENTS

CAUTION: Do not make current measurements on the 10A scale for longer than 30 seconds. Exceeding 30 seconds may cause damage to the meter and/or the test leads.

1. Insert the black test lead banana plug into the negative (**COM**) jack.
2. For current measurements up to 6000 μ A DC, set the function dial to the **μ A** position and insert the red test lead into the positive **μ A** jack.
3. For current measurements up to 600mA DC, set the function dial to the **mA** range and insert the red test lead into the positive **mA** jack.
4. For current measurements up to 10A DC, set the function dial to the **10A** position and insert the red test lead into the **10A** jack.
5. Press the **MODE** button until the **DC** icon appears on the left side of the display.
6. Remove power from the circuit under test, then open up the circuit at the point where you wish to measure current.
7. Touch the black test probe tip to the negative side of the circuit. Touch the red test probe tip to the positive side of the circuit.
8. Apply power to the circuit.
9. Read the current value on the display. The display will indicate the proper decimal point, value and symbol.

AC CURRENT MEASUREMENTS

WARNING: To avoid electric shock, do not measure AC current on any circuit where voltage exceeds 250V AC.

CAUTION: Do not make current measurements on the 10A scale for longer than 30 seconds. Exceeding 30 seconds may cause damage to the meter and/or the test leads.

1. Insert the black test lead into the negative (**COM**) jack.
2. For current measurements up to $6000\mu\text{A AC}$, set the function dial to the μA position and insert the red test lead into the positive μA jack.
3. For current measurements up to 600mA AC , set the function dial to the **mA** range and insert the red test lead into the positive **mA** jack.
4. For current measurements up to 10A AC , set the function dial to the **10A** position and insert the red test lead into the **10A** jack.
5. Press the **MODE** button until **AC** icon appears on the right side of the display.
6. Remove power from the circuit under test, then open the circuit at the point where you wish to measure current.
7. Touch the black test probe tip to the negative side of the circuit and the red test probe tip to the positive side of the circuit.
8. Apply power to the circuit.
9. Read the current on the display. The display will indicate the proper decimal point, value and symbol.

RESISTANCE MEASUREMENTS

WARNING: To avoid electric shock, disconnect power to the unit under test and discharge all capacitors before taking any resistance measurements.

1. Set the function switch to the $\Omega \rightarrow \text{cap}$ position and press the **MODE** key to select the resistance mode.
2. Insert the black test lead into the negative (**COM**) jack and the red test lead into the positive (Ω) jack.
3. Touch the test probe tips to either side of the circuit or part under test. It is best to disconnect one side of the part

under test so the rest of the circuit will not interfere with the resistance reading.

4. Read the resistance value on the display. The display will indicate the proper decimal point, value and symbol.

CAPACITANCE MEASUREMENTS

WARNING: To avoid electric shock, disconnect power to the unit under test and discharge all capacitors before taking any capacitance measurements.

1. Set the function dial to the $\Omega \rightarrow \text{cap}$ position, and press **MODE** button to select the capacitance mode.
2. Insert the black test lead into the negative (**COM**) jack and the red test lead into the positive (Ω) jack.
3. Touch the test probe tips to either side of the circuit or part under test. It is best to disconnect one side of the part under test so the rest of the circuit will not interfere with the resistance reading.
4. Read the capacitance value in the display. The display will indicate the proper decimal point, value and symbol.

NOTE: In order to obtain an accurate reading, a capacitor must be discharged before measurement begins.

CONTINUITY CHECK

WARNING: To avoid electric shock, never measure continuity on circuits or wires that have voltage on them.

1. Set the function dial to the $\Omega \rightarrow \text{cap}$ position, and press the **MODE** button until the \rightarrow symbol appears on the top of the display.
2. Insert the black lead into the negative (**COM**) jack and

2. Insert the black test lead into the negative (**COM**) jack and the red test lead into the positive (**HZ%**) jack.
3. Touch the test probe tips to the circuit under test.
4. Read the frequency on the display. The digital reading will indicate the proper decimal point, symbols (Hz, kHz, MHz) and value.

NOTE: Press the **MODE** button to select the frequency or the duty ratio.

TEMPERATURE MEASUREMENTS

WARNING: To avoid electric shock, disconnect all test probes from any source of voltage before making a temperature measurement.

1. Set the function dial to the **°C/°F** position and press the **MODE** button to select between **°C** (Celsius) and **°F** (Fahrenheit).
2. Insert the Temperature Probe(s) into the Temperature Socket, making sure to observe the correct polarity.
3. Place the Temperature Probe tip to the part whose temperature you wish to measure. Keep the probe touching the part under test until the reading stabilizes (about 30 seconds).
4. Read the temperature on the display. The digital reading will indicate the proper decimal point and value.

WARNING: To avoid electric shock, be sure the thermocouple has been removed before changing to another measurement function.

REPLACING THE BATTERY

WARNING: To avoid electric shock, disconnect the test leads from any source of voltage before removing the fuse/battery cover.

1. When the battery needs to be replaced  will appear on the left-hand side of the LCD display.
2. To replace the battery, disconnect all test leads and remove the battery cover by loosening the two screws using a Phillips head screwdriver.
3. Remove old battery and insert new battery into battery holder, observing correct polarity. Replace battery cover and secure with two screws.
4. Properly dispose of old battery.

WARNING: To avoid electric shock, do not operate your meter until the battery door is in place and fastened securely.

CAUTION: To avoid potential damage to the meter, always remove the battery if the meter will be stored for longer than 60 days.

NOTE: If your meter does not work properly, check the fuses and battery to make sure that they are still good and that they are properly inserted.

REPLACING THE FUSES

WARNING: To avoid electric shock, disconnect the test leads from any source of voltage before removing the fuse/battery cover.

1. Disconnect the test leads from the meter and any item under test.
2. Remove the fuse/battery cover by loosening the two screws using a Phillips head screwdriver.
3. Remove the old fuse from its holder by gently pulling it out.
3. Install the new fuse into the holder.
4. Always use a fuse of the proper size and value (0.8A/250V fast blow for the 600mA range, 10A/250V fast blow for the 10A range).
5. Replace the battery cover and secure with two screws.

WARNING: To avoid electric shock, do not operate your meter until the fuse door is in place and fastened securely.

Warranty

This PDI product is warranted to be free from defects in materials and workmanship for a period of two (2) years from the verified date of purchase. During this warranty period, PDI will either repair or replace the defective unit, at PDI's discretion. A purchase receipt or other acceptable form of proof of original purchase date will be required before any warranty processes begin. PDI warrants all authorized repairs with a six (6) month limited warranty.

View full warranty details and register your PDI product at www.PDIimeters.com.

NOTE: Online product registration is required for all warranty claims. All warranty claims must have a Return Goods Authorization assigned from PDI, in order to begin processing. Contact PDI for more details.



Precision Diagnostic Instruments

7581 W. 103rd Ave.

Westminster, CO 80021

Tel: 1-800-453-7892

Fax: 303-650-1238